

NEWTON

Underwater Laser Scanner M210UW

Operates as standalone system or fully integrated with IMU data correction for dynamic scanning



Underwater Laser Scanners that capture sub-millimeter measurement for underwater metrology.

Product Details

- Depth rated up to 100m
- ROV/AUV mounted or cable served
- Requires GigEthernet, one serial line and 36VDC from the ROV/AUV
- Live camera view allows operator to achieve maximum productivity
- Captures from within 150mm to 900mm
- Combine multiple scans into comprehensive CAD model

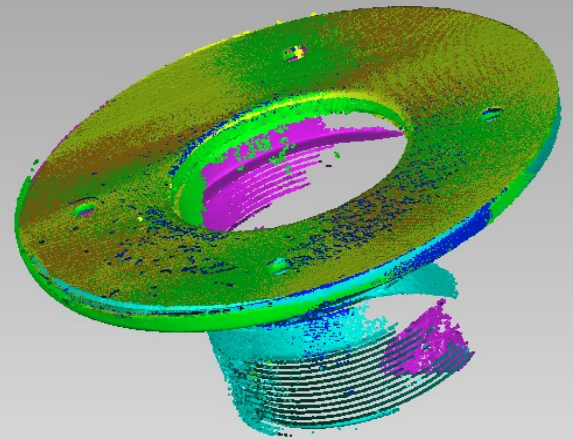

Depth of Field (Distance to Object)	Field of View Width—Height	Approximate CAD Model Accuracy
150 mm	190mm x 150mm	0.01 mm
300 mm	330 mm x 250mm	0.02 mm
450 mm	470mm x 350mm	0.03mm
600 mm	600mm x 450mm	0.06mm
900 mm	880mm x 650mm	0.15 mm

Above—Combine multiple scans for composite 3D analysis.

*Accuracy statements on left are based on post processing of scanner's raw point cloud data. Scanning conditions can effect the raw data acquisition, but post process can be used to filter out noise in the data.

For dynamic scanning, IMU accuracy and speed of travel impacts final scan results

Underwater Laser Scanning - M210UW

Underwater Laser Scanning exceeds traditional underwater measurements by capturing as built point cloud data with sub-millimeter accuracy. The data captured by the Newton underwater laser scanners leaves asset managers and engineers with absolute confidence in their measurement data.



Newton Scanner Operation

- **Dual Usage** The M210UW can operate with a fixed laser line and IMU data as well as the standard internal high resolution scanning.
- **The Newton scanners operate by triangulation** - The laser sweeps the target and the high resolution camera records any deformation of the beam as a point cloud.
- **The scanners scans a target** as distant as 1m and as close as 0.15m, for a scan coverage area up to 880mm x 650mm. The system measures underwater targets up to an accuracy of 0.01 mm* (see front).
- **Scanner software can capture much larger target areas** by combining several point clouds together in post processing to form larger composites.
- **Operators may select from several levels of scan quality.** The shortest, coarse scan takes 15 seconds; the longest and most detailed takes about three minutes
- **Deployment of the scanner head** is designed for fixed, diver or ROV/AUV deployment and has simple mounting holes on the back panel .

Product Dimensions

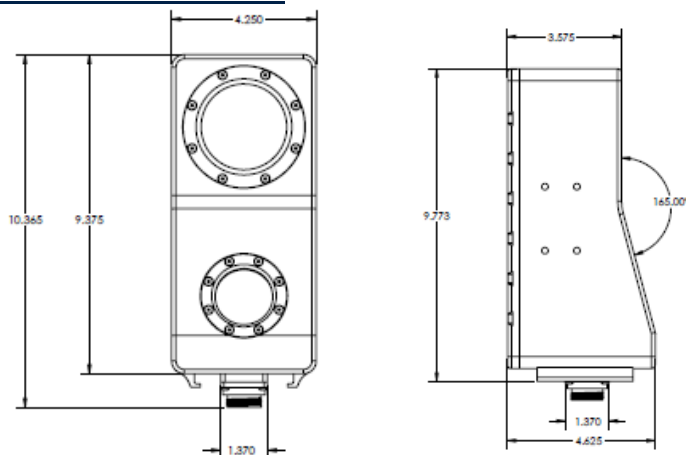

Technical Specifications:

Measurement Range	Between 0.15m and 1m
Power Requirements Newton Control Unit	Power 110 to 240 50/60 Hz VAC to the Control Unit (the Control Unit provide power to the sensor)
ROV/AUV MUX	Requires 36v at 3amps , Serial and Gig Ethernet
Cable	Custom for ROV Cable Served 30m standard Up to 100m Available
Weight	M210UW– 8bs in air, 2 lbs in water
Scanner Head Dimensions	See Below
Control Unit Dimensions	24.60" x 19.70" x 11.70" (62.5 x 50 x 29.7 cm) Laptop Option Available
Control Unit Weight	56 lbs (25 kg) Laptop Option Available
Display	19" (48 cm) Color
Depth Rating	100m

About Newton Labs

Newton Labs is a Seattle area-based privately held developer and manufacturer of laser scanners, machine vision and robotic systems. Newton's powerful, easy to use, and industrially rugged systems provide solutions for wide ranging applications in many sectors, including aerospace, automotive, bottling, electronics, medical, packaging, and nuclear, among others. In more than 20 years Newton has deployed more than 30,000 machine vision and automaton systems worldwide, many that are first-of-a-kind.